

MP series

1,600kg / 1,800kg / 2,000kg / 2,200kg

Powered Pallet Truck



- Ergonomic tiller head and mid mounted tiller arm offer excellent operator comfort
- Compact powerhead length and creep speed for excellent manoeuvrability
- 3 preset performance settings to suit driver preferences
- AC drive motor
- On-board charger option

Truck Dimensions

$$Ast = Wa + R + a$$

$$Ast = Wa + \sqrt{(l_6 - x)^2 + (b_{12} / 2)^2} + a$$

a = 200mm

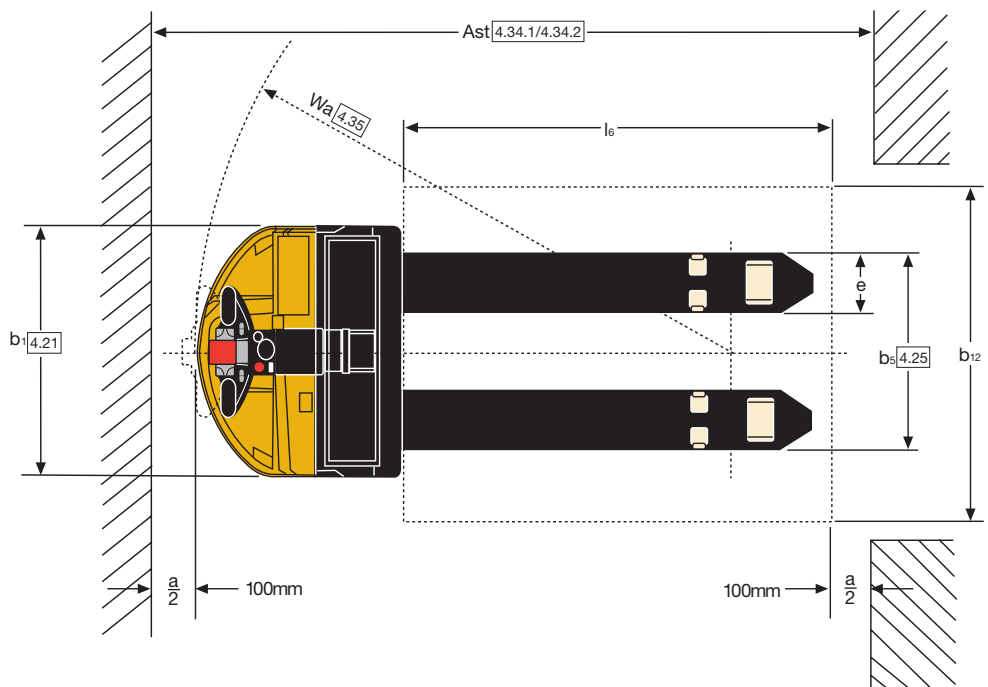
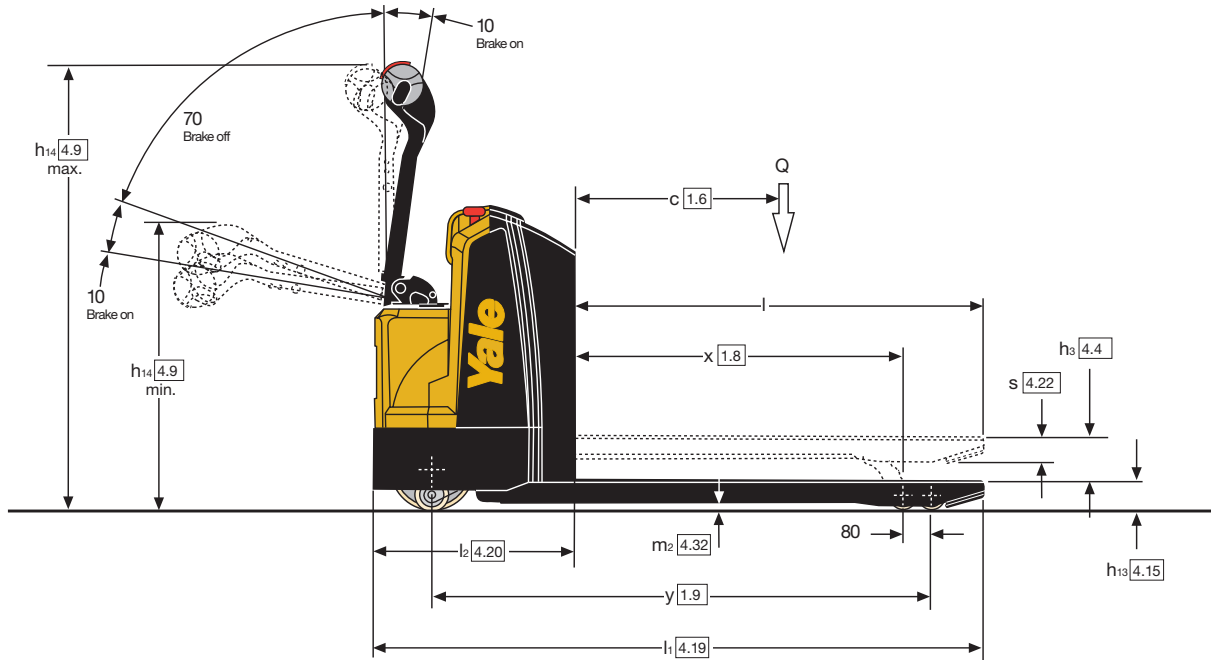

VDI 2198 – General Specifications

			Yale	Yale	Yale	Yale	
Distinguishing mark	1.1	Manufacturer (abbreviation)		Yale	Yale	Yale	Yale
	1.2	Manufacturer's type designation		MP16	MP18	MP20	MP22
	1.3	Drive: electric (battery or mains), diesel, petrol, fuel gas		Electric (battery)	Electric (battery)	Electric (battery)	Electric (battery)
	1.4	Operator type: hand, pedestrian, standing, seated, order-picker		Pedestrian	Pedestrian	Pedestrian	Pedestrian
	1.5	Rated capacity/Rated load	Q (t)	1.6	1.8	2.0	2.2
	1.6	Load centre distance ⁽²⁾	c (mm)	600	600	600	600
	1.8	Load distance, centre of drive axle to fork ⁽²⁾	x (mm)	955	955	955	955
	1.9	Wheelbase ⁽²⁾	y (mm)	1368	1368	1440	1440
	Weights	2.1	Service weight ^{(2) (3)}	kg	545	545	632
2.2		Axle loading, laden front/rear ⁽²⁾	kg	841 / 1304	893 / 1452	983 / 1649	1032 / 1800
2.3		Axle loading, unladen front/rear ⁽²⁾	kg	425 / 120	425 / 120	489 / 143	489 / 143
Tyres/chassis	3.1	Tyres: polyurethane, tophane, vulkollan, front/rear		Polyurethane	Polyurethane	Polyurethane	Polyurethane
	3.2	Tyre size, front	ø (mm x mm)	250 x 75	250 x 75	250 x 75	250 x 75
	3.3	Tyre size, rear	ø (mm x mm)	85 x 110	85 x 110	85 x 110	85 x 110
	3.4	Additional wheels (dimensions)	ø (mm x mm)	100 x 40	100 x 40	100 x 40	100 x 40
	3.5	Wheels, number front/rear (x = driven wheels)		1x + 2 / 2	1x + 2 / 2	1x + 2 / 2	1x + 2 / 2
	3.6	Tread, front	b ₁₀ (mm)	461	461	461	461
	3.7	Tread, rear	b ₁₁ (mm)	390	390	390	390
Dimensions	4.4	Lift	h ₃ (mm)	130	130	130	130
	4.9	Height of tiller arm in driving position min./max.	h ₁₄ (mm)	744 / 1221	744 / 1221	744 / 1221	744 / 1221
	4.15	Height, lowered	h ₁₃ (mm)	85	85	85	85
	4.19	Overall length ⁽²⁾	l ₁ (mm)	1734	1734	1806	1806
	4.20	Length to face of forks ⁽²⁾	l ₂ (mm)	578	578	650	650
	4.21	Overall width	b ₁ / b ₂ (mm)	712	712	712	712
	4.22	Fork dimensions DIN ISO 2331 ⁽²⁾	s/e/l (mm)	64 / 172 / 1156	64 / 172 / 1156	64 / 172 / 1156	64 / 172 / 1156
	4.25	Outside fork width	b ₅ (mm)	560	560	560	560
	4.32	Ground clearance, centre of wheelbase	m ₂ (mm)	21	21	21	21
	4.34.1	Aisle width for pallets 1000mm x 1200mm crossways ⁽²⁾	A _{st} (mm)	2337	2337	2409	2409
4.34.2	Aisle width for pallets 800mm x 1200mm lengthwise ⁽²⁾	A _{st} (mm)	2204	2204	2276	2276	
4.35	Turning radius (pedestrian) ⁽²⁾	W _a (mm)	1535	1535	1607	1607	
Performance data	5.1	Travel speed, laden/unladen	km/h	6 / 6	6 / 6	6 / 6	6 / 6
	5.1.1	Travel speed, laden/unladen, backwards	km/h	6 / 6	6 / 6	6 / 6	6 / 6
	5.2	Lift speed, laden/unladen	m/s	0.04 / 0.05	0.04 / 0.05	0.04 / 0.05	0.04 / 0.05
	5.3	Lowering speed, laden/unladen	m/s	0.09 / 0.04	0.09 / 0.04	0.09 / 0.04	0.09 / 0.04
	5.7	Gradeability, laden/unladen	%	5.5 / 15	5 / 15	4.5 / 15	4 / 15
	5.8	Max. gradeability, laden/unladen	%	10 / 20	9 / 20	8 / 20	7.5 / 20
5.10	Service brake		Electromagnetic	Electromagnetic	Electromagnetic	Electromagnetic	
Electric engine	6.1	Drive motor S2 60 minute rating	kW	1.25	1.25	1.25	1.25
	6.2	Lift motor, S3 15% rating	kW	1.2	1.2	1.2	1.2
	6.3	Battery according to DIN 43531/35/36 A,B,C, no ⁽⁴⁾		Din 43535 B	Din 43535 B	Din 43535 B	Din 43535 B
	6.4	Battery voltage/nominal capacity K _s ^{(1) (2)}	(V)/(Ah)	24 / 250	24 / 250	24 / 375	24 / 375
	6.5	Battery weight ^{(2) (3)}	kg	212	212	288	288
	6.6	Energy consumption according to VDI cycle	kWh/h at no. of cycles	0.384	0.384	0.384	0.384
8.1	Type of drive unit		AC-Controller	AC-Controller	AC-Controller	AC-Controller	
10.7	Sound pressure level at the driver's seat	dB (A)	< 70	< 70	< 70	< 70	

On MP16 / MP18 available batteries 150Ah, 210Ah.

⁽¹⁾ On MP20 available batteries 150Ah, 210Ah, 250Ah, 315Ah.

On MP22 available batteries 210Ah, 250Ah, 315Ah.

⁽²⁾ See "Batteries table".

⁽³⁾ These values may vary of +/- 5%.

⁽⁴⁾ 150Ah battery is not DIN 43635 B.

All values are nominal values and they are subject to tolerances.

For further information, please contact the manufacturer.

Yale products might be subject to change without notice.

Lift trucks illustrated may feature optional equipment.

Values may vary with alternative configurations.

Battery compartment 375 / 315 Ah (b₅ = 520mm - 560mm - 670mm)

Distinguishing mark	1.6	Load centre distance	c (mm)	400	500	600	700	800				
	1.8	Load distance, centre of drive axle to fork	x (mm)	599	805	955	1199	1399				
	1.9	Wheelbase	y (mm)	1084	1290	1440	1684	1884				
Weights	2.1	Service weight ⁽¹⁾	kg	612	623	632	646	657				
	2.2	Axle loading, laden ⁽³⁾	kg front	809	944	983	1106	1166				
			kg rear	1803	1679	1649	1540	1491				
	2.3	Axle loading, unladen	kg front	441	471	489	513	529				
			kg rear	171	152	143	133	128				
Dimensions	4.19	Overall length	l ₁ (mm)	1450	1656	1806	2050	2250				
	4.20	Length to face of forks	l ₂ (mm)	650	650	650	650	650				
	4.22	Fork dimensions ISO 2331	l (mm)	800	1006	1156	1400	1600				
	4.34.1	Aisle width for pallets 1000mm x 1200mm wide	A _{st} (mm)	2173	2288	2409	2683	2972				
	4.34.2	Aisle width for pallets 800mm x 1200mm long	A _{st} (mm)	2173	2219	2276	2451	2698				
	4.35	Turning radius	W _a (mm)	1251	1457	1607	1851	2051				
Electric-engine	6.4	Battery voltage / capacity at 5 hours rate ⁽²⁾	(V) / (Ah)	24 / 375 - 315								
	6.5	Battery weight ⁽¹⁾	kg	288								

Battery compartment 250 / 210Ah (b₅ = 520mm - 560mm - 670mm)

Distinguishing mark	1.6	Load centre distance	c (mm)	400	500	600	700	800	400	500	600	700	800
	1.8	Load distance, centre of drive axle to fork	x (mm)	599	805	955	1199	1399	599	805	955	1199	1399
	1.9	Wheelbase	y (mm)	1012	1218	1368	1612	1812	1012	1218	1368	1612	1812
Weights	2.1	Service weight ⁽¹⁾	kg	525	536	545	559	570	499 ⁽⁵⁾	510 ⁽⁵⁾	519 ⁽⁵⁾	533 ⁽⁵⁾	544 ⁽⁵⁾
	2.2	Axle loading, laden ⁽³⁾	kg front	776	910	945	1066	1123	768	771	774	909	945
			kg rear	1749	1626	1600	1493	1447	1731	1739	1745	1624	1599
	2.3	Axle loading, unladen	kg front	382	409	425	447	461	363	371	378	407	424
			kg rear	143	127	120	112	109	136	139	141	126	120
Dimensions	4.19	Overall length	l ₁ (mm)	1378	1584	1734	1978	2178	1378	1584	1734	1978	2178
	4.20	Length to face of forks	l ₂ (mm)	578	578	578	578	578	578	578	578	578	578
	4.22	Fork dimensions ISO 2331	l (mm)	800	1006	1156	1400	1600	800	1006	1156	1400	1600
	4.34.1	Aisle width for pallets 1000mm x 1200mm wide	A _{st} (mm)	2101	2216	2337	2611	2900	2101	2216	2337	2611	2900
	4.34.2	Aisle width for pallets 800mm x 1200mm long	A _{st} (mm)	2101	2147	2204	2379	2626	2101	2147	2204	2379	2626
	4.35	Turning radius	W _a (mm)	1179	1385	1535	1779	1979	1179	1385	1535	1779	1979
Electric-engine	6.4	Battery voltage / capacity at 5 hours rate ⁽²⁾	(V) / (Ah)	24 / 250 - 210						24 / 250 ⁽⁴⁾			
	6.5	Battery weight ⁽¹⁾	kg	212						180			

Battery compartment 150Ah (b₅ = 520mm - 560mm - 670mm)

Distinguishing mark	1.6	Load centre distance	c (mm)	400	500	600	700	800	400	500	600	700	800
	1.8	Load distance, centre of drive axle to fork	x (mm)	599	805	955	1199	1399	599	805	955	1199	1399
	1.9	Wheelbase	y (mm)	950	1156	1306	1550	1750	950	1156	1306	1550	1750
Weights	2.1	Service weight ⁽¹⁾	kg	449	460	469	483	494	430	441	450	464	475
	2.2	Axle loading, laden ⁽³⁾	kg front	748	881	912	1032	1086	729	862	893	1013	1067
			kg rear	1701	1579	1557	1451	1408	1701	1579	1557	1451	1408
	2.3	Axle loading, unladen	kg front	328	352	367	387	400	314	337	352	371	384
			kg rear	121	108	102	96	94	116	104	98	93	91
Dimensions	4.19	Overall length	l ₁ (mm)	1316	1522	1672	1916	2116	1316	1522	1672	1916	2116
	4.20	Length to face of forks	l ₂ (mm)	516	516	516	516	516	516	516	516	516	516
	4.22	Fork dimensions ISO 2331	l (mm)	800	1006	1156	1400	1600	800	1006	1156	1400	1600
	4.34.1	Aisle width for pallets 1000mm x 1200mm wide	A _{st} (mm)	2039	2154	2275	2549	2838	2039	2154	2275	2549	2838
	4.34.2	Aisle width for pallets 800mm x 1200mm long	A _{st} (mm)	2039	2085	2142	2317	2564	2039	2085	2142	2317	2564
	4.35	Turning radius	W _a (mm)	1117	1323	1473	1717	1917	1117	1323	1473	1717	1917
Electric-engine	6.4	Battery voltage / capacity at 5 hours rate ⁽²⁾	(V) / (Ah)	24 / 150						24 / 250 ⁽⁴⁾			
	6.5	Battery weight ⁽¹⁾	kg	144						125			

⁽¹⁾ These values may vary of +/- 5%

⁽²⁾ Battery type Din 43535 B (with the exception of 150Ah battery)

⁽³⁾ Axle loading with LOAD = 2000Kg

⁽⁴⁾ Polypropylene case version

⁽⁵⁾ Includes ballast 6 kg

All values are nominal values and they are subject to tolerances.

For further information, please contact the manufacturer. Yale products might be subject to change without notice.

Lift trucks illustrated may feature optional equipment. Values may vary with alternative configurations.

Tiller Head

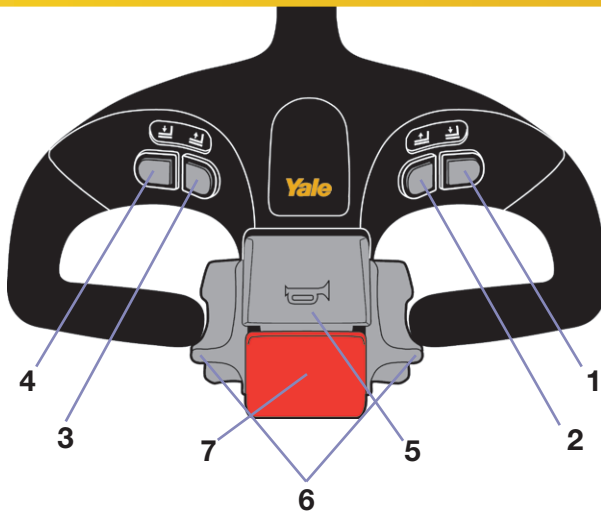

- 1 Fork lowering
- 2 Fork lifting
- 3 Lift frame
- 4 Lower frame
- 5 Horn
- 6 Forward/reverse control speed
- 7 Reverse gear button



MP series

Models: MP16, MP18, MP20, MP22



Yale® MP Series pedestrian low lift pallet trucks combine the latest in state-of-the-art technology and ergonomics making Yale the leader for pallet trucks applications.

Tiller head and controls

The tiller head is designed for operator comfort and features an ergonomic shaped handle with angled grips and integral hand guard. Large dimensioned, low effort butterfly buttons control direction of travel and speed as well as the electromagnetic brake. All controls are accessible without having to lift the hand from the handle. Dual lift and lower buttons are conveniently located on the tiller head and can be readily accessed for left or right hand use.

The travel direction inverter emergency button is designed for maximum angle of contact with the operator's body. When activated, the direction of travel is automatically reversed and the truck comes to a stop. The horn is located on top of the tiller head and conveniently actuated by thumb or forefinger.

Tiller arm

The tiller arm is mid mounted increasing fork tips visibility while the tiller arm ensure the operating clearance when walking inside the truck envelope. The tiller arm is spring assisted and returns automatically to the vertical position when released. The creep speed control allows the truck to be operated with the tiller arm in the

vertical position at reduced speed for manoeuvring in tight confines.

Driver Selectable Performance Modes

The truck offers a choice of three pre-programmed performance modes that are selectable through the control handle easily selectable to suit driver preference. These modes alter the acceleration, deceleration and top speed of the truck, enabling the performance of the truck to be optimized for the particular work environment or the work cycle.

Electrical System

The MP Series electrical system is designed with uptime and reliability in mind. Industry leading technology, CANbus Communications, Hall Effect Sensors, Proximity Switches and Transistor Controller are incorporated into the design, reducing the number of wires, connectors, switches and contactors. The 200 Amp AC transistorized motor controller provides improved acceleration and high performance top speeds when loaded. A standard display gauge allows for viewing of hour meter and battery state of charge. All units are equipped with low battery lift interrupt.

Traction System

The AC traction system consists of the traction motor, gearbox, and brake. The traction motor is vertically mounted and fully enclosed to shield it from contamination and is fixed to eliminate flexing stresses to the power cable during cornering. The proven gearbox design includes a large, maintenance free, sealed turntable steer bearing. Heat treated gears are lubricated in an oil bath to provide long life.

Brake

The electromagnetic brake is electrically released and spring applied. The brake is opened and closed by activation of the butterfly buttons with the tiller arm in the working position. The brake is closed by bringing the tiller arm to the vertical or horizontal position. Reverse current braking is applied by inverting the direction of travel. Releasing the butterfly buttons induces both reverse current braking (adjustable) and regenerative braking. The maintenance free electromechanical brake is top mounted on the traction motor, shielding it from debris and contamination.



Options

- Lateral battery extraction - MP18 -22
- Different battery compartments - see tables on page 4.
- Battery cable extension
- Key pad start
- Various fork lengths
- 520mm or 670mm overall fork width
- Cold store -30°C
- Drive tyre options:
 - Tophane drive tyre
 - Vulkollan drive tyre
- Tandem polyurethane load wheels
- Load backrest
- Smart Slow Down™
- Smart Lift™
- Audible alarm
- 36 months/6000 hrs extended warranty.

Traction and pump control

A MOSFET high frequency controller is used to regulate traction and pump operation. Energy efficient, smooth progressive control is available at all times. The controller features automatic braking (reverse current braking) and regenerative braking on release of the butterfly buttons as well as anti-rollback start-up on an incline. The controller features an in-built diagnostic system and alarm history as well as thermal protection.

Hydraulic Components

The lift pump and motor assembly features a 1.2 kW permanent magnet motor and translucent hydraulic tank. The permanent magnet motor provides high efficiency and low noise. The hydraulic pump is controlled directly by the controller. Lift and lower functions are actuated directly from the tiller head controls.

The lift interrupt feature is standard on all models. The translucent tank provides quick and easy inspection of hydraulic oil level.

Forks and Frame

The heavy duty, formed, boxed-in, steel forks are fabricated for strength and robustness. An integrated fork torsion box, heavy duty torsion bar and linkage all work together to reduce torsional twisting and load sway. The highly engineered heavy duty drive frame casting and weldment are the backbone

of the MP series. All pivot points incorporate “X” groove bushings and hardened, nickel-plated flag pins to resist corrosion.

All pivot points include high pressure grease fittings for servicing.

Pallet Entry and Exit

Yale® fork design provides both standard and optional features to allow repositioning of pallets and enhances pallet entry.

Wheels, Tyres, and Casters

The standard load wheel configuration is a single load wheel with two roller bearings for long life. A “knock-out” axle provides for quick and easy maintenance. A polyurethane drive tyre is standard.

Battery Pack and Charger

Various choices of battery compartment sizes, power alternatives, and on-board, chassis mounted smart chargers are available.

To charge the batteries using on board charger, simply plug the power cord into the battery charge port and outlet. The charger automatically prevents the truck from being operated.

Additional Features

Standard equipment includes key switch, electronic horn, Creep Speed, cowl mounted emergency button and battery discharge indicator with hour meter display.

MP series

Models: MP16, MP18, MP20, MP22



HYSTER-YALE UK LIMITED

trading as **Yale Europe Materials Handling**
Centennial House, Frimley Business Park,
Frimley, Surrey GU16 7SG, United Kingdom.



Tel: +44 (0) 1276 538500
Fax: +44 (0) 1276 538559

www.yale-forklifts.eu



Publication part no. 220990129 Rev.04 Printed in The Netherlands (0118HG) EN.

Safety: This truck conforms to the current EU requirements. Specification is subject to change without notice.

Yale, VERACITOR and  are registered trademarks. "PEOPLE, PRODUCTS, PRODUCTIVITY", PREMIER, Hi-Vis, and CSS are trademarks in the United States and certain other jurisdictions. MATERIALS HANDLING CENTRAL and MATERIAL HANDLING CENTRAL are Service Marks in the United States and certain other jurisdictions.  is a Registered Copyright.

©Yale Europe Materials Handling 2018. All rights reserved. Truck shown with optional equipment.
Country of Registration: England and Wales. Company Registration Number: 02636775